



Descripción del problema:

- Obtención de un modelo canónico extendido del A.O.V. de pequeña señal
- Uso de A.O.V.'s no compensados internamente
- Compensación local de A.O.V. con redes complejas (en gral. cuadripolos)
- Realimentación local activa

Características de transferencia del A.O.V.:

Ideal:

- Ganancia de lazo abierto infinita
- Ancho de banda infinito
- Impedancia de entrada infinita
- Impedancia de salida nula
- Linealidad de ganancia
- Linealidad dinámica
- RRMC y RRS infinita

Real:

- Ganancia de lazo abierto finita función de ω
- Ancho de banda finito
- Impedancia de entrada finita función de ω
- Impedancia de salida no nula función de ω
- Varias causas de alinealidad estática
- Varias causas de alinealidad dinámica
- RRMC y RRS finita

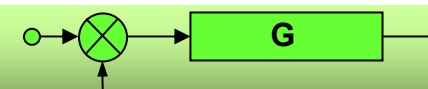
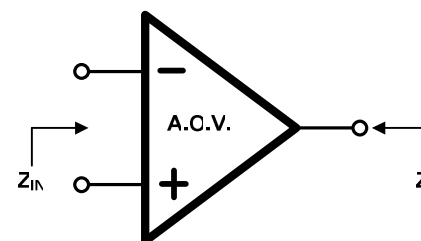



Modelo interno del A.O.V.:

Modelo simplificado del TBJ

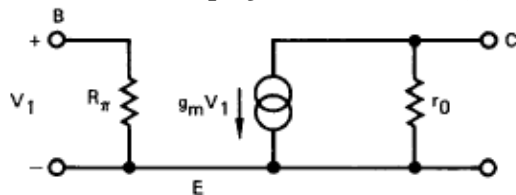

$$r_e \cong \frac{k \cdot T}{q \cdot I_1}$$

$$g_{m1} \cong \frac{q \cdot I_1}{k \cdot T}$$

$$r_{\pi} \cong \beta_0 \cdot r_e \cong \frac{\beta_0}{g_m}$$

GANANCIA EN DC

$$A_V(0) = \frac{V_{OUT}}{V_{in}} \cong \frac{g_{m1} \beta_5 \beta_6 \beta_7 R_L}{1 + r_{i2} / r_{01}'}$$

$$r_{i2} \cong \beta_5 (r_{e5} + \beta_6 \cdot r_{e6})$$

$$r_{01}' \cong (r_{04} \parallel r_{02})$$

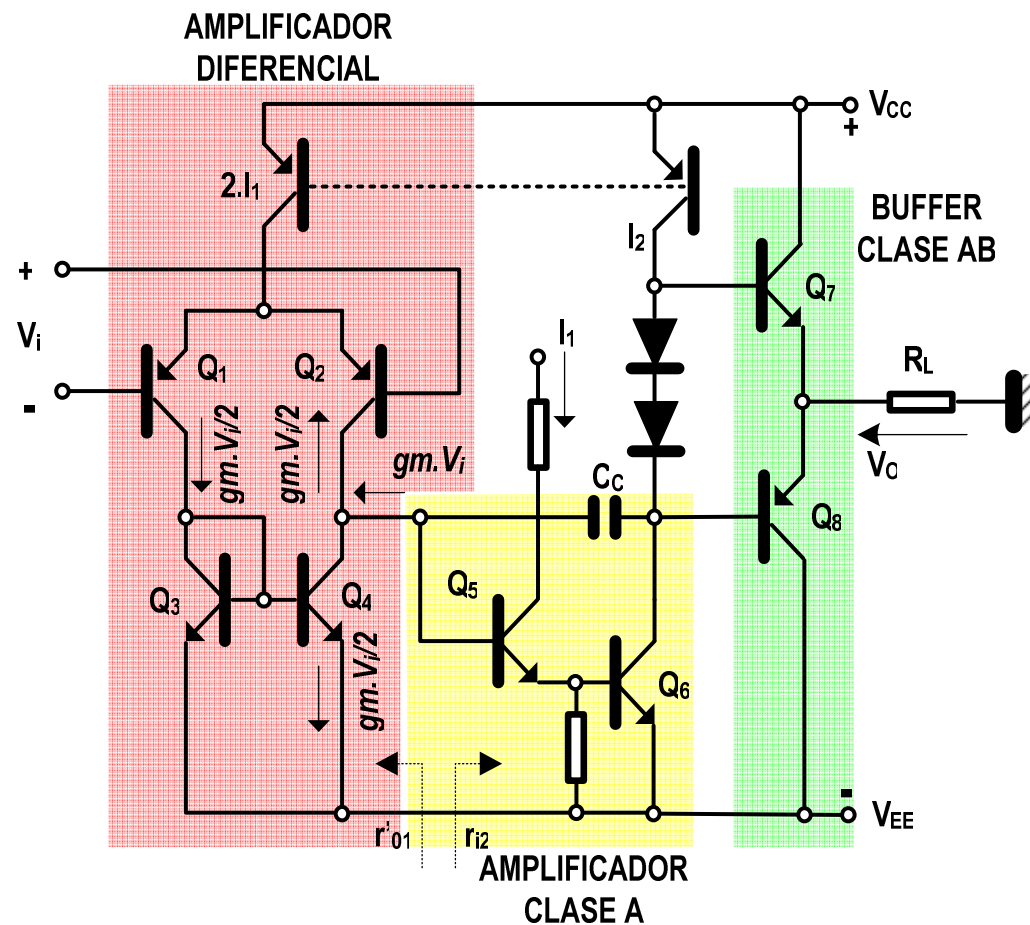

James Solomon, The Monolithic Operational Amplifier: A Tutorial Study, National Semiconductor, Dic 1974

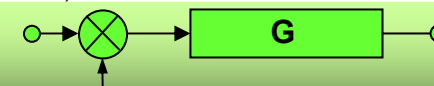



Modelo interno del A.O.V. (cont.):

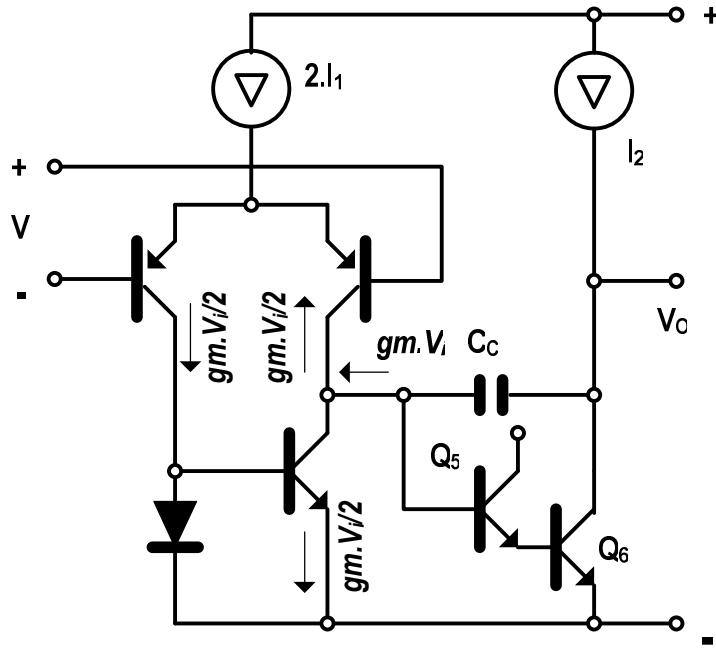

≡

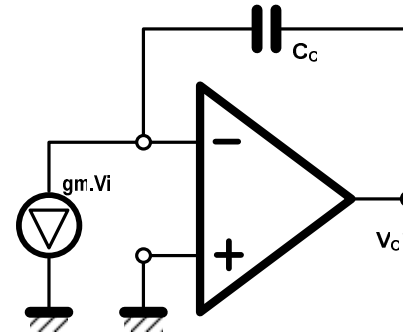

$$\frac{V_o(s)}{V_i(s)} \approx \frac{gm}{s \cdot C_c}$$

CALCULO DEL POLO DOMINANTE

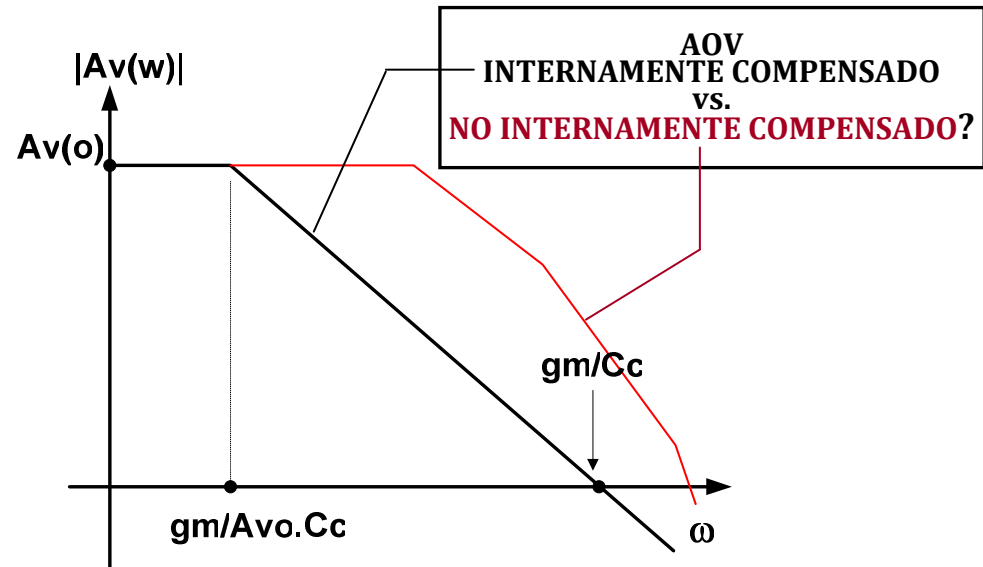

GANANCIA EN DC

$$A_v(0) = \frac{v_{out}}{v_{in}} \approx \frac{9m_1\beta_5\beta_6\beta_7R_L}{1 + r_{i2}/r_{o1}'}$$

$$r_{i2} \approx \beta_5(r_{e5} + \beta_6 r_{e6})$$

$$r_{o1}' \approx r_{o4} // r_{o2}$$

Ejemplo: LM101

$R_L=2k; \beta_5=\beta_6=150$

$I_1=10\mu A; I_2=300\mu A$

$\beta_7=50$

$A_v(0)=625000$

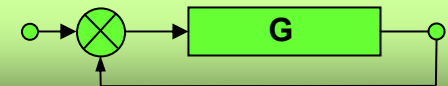

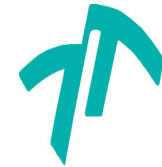

Modelo interno del A.O.V. (cont.):

REALIMENTACION TERMICA

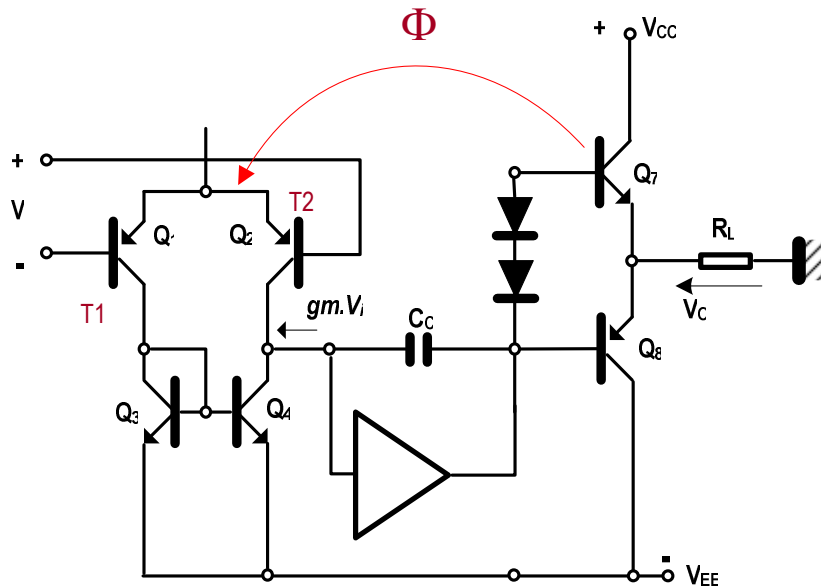

$$\Delta V_{IN(TH)} = (T_2 - T_1) \cdot (-2.2mV / ^\circ C) = \pm \Delta R_{TH} \cdot P_D \cdot (-2.2mV / ^\circ C)$$

$$P_D = \frac{V_O \cdot (V_{SS} - V_O)}{R_L}$$

$$\beta_{TH} = \frac{\partial V_{IN(TH)}}{\partial V_O} = \pm \Delta R_{TH} \cdot \frac{(-2.2mV / ^\circ C) \cdot (V_{SS} - 2V_O)}{R_L}$$

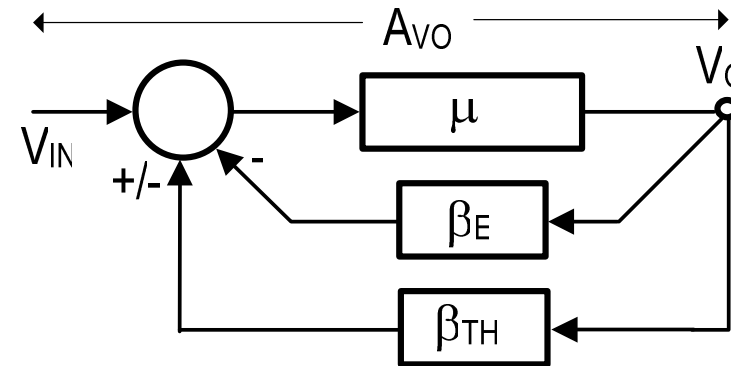

Estabilidad => $\beta_E > \beta_{TH}$

$$A_V(0) = \frac{\mu}{1 + \mu \cdot (\beta_E \pm \beta_{TH})}$$

$$\beta_E = 0 \Rightarrow A_V(0)_{MAX} \cong \frac{1}{\beta_{TH}_{MAX}} = \frac{R_L}{\Delta R_{TH} \cdot 2.2mV / ^\circ C \cdot V_{SS}}$$

EL DISEÑO TERMICO DEFINE LA MAXIMA GANANCIA DISPONIBLE (empeora en AOV de potencia)

Ejemplo:

$$V_{SS} = 15V \quad \Delta R_{TH} = 0.3^\circ C/W \quad R_L = 2K$$

$$A_V(0)_{MAX} = 202000 (< 625000)$$





Modelo interno del A.O.V. (cont.):

SLEW RATE LIMIT

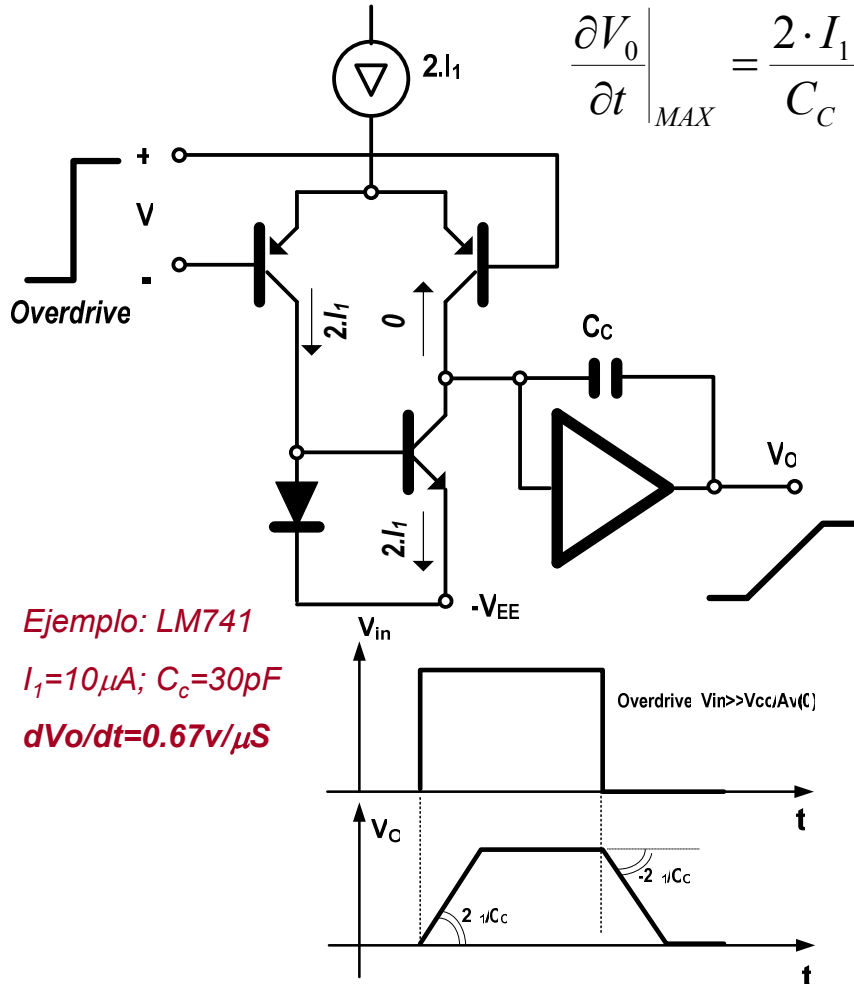

Ancho de banda de potencia máxima ω_P :

$$\left. \frac{\partial V_0}{\partial t} \right|_{MAX} = \frac{2 \cdot I_1}{C_C} = \omega_B \cdot V_{OPk}|_{MAX} \approx \omega_B \cdot V_{SS}$$

$$\omega_B \approx \frac{2 \cdot I_1}{V_{SS} \cdot C_C}$$

Ancho de banda de pequeña señal ω_S :

$$\omega_S \cong \frac{gm}{C_C} \approx \frac{q \cdot I_1}{k \cdot T \cdot C_C} \approx \frac{I_1}{26mV \cdot C_C}$$

Relación de ancho de banda:

$$\frac{\omega_S}{\omega_P} \approx \frac{V_{SS}}{52mV}$$

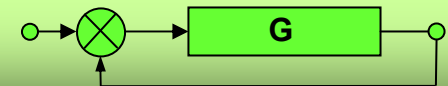



Análisis general de AOV realimentados

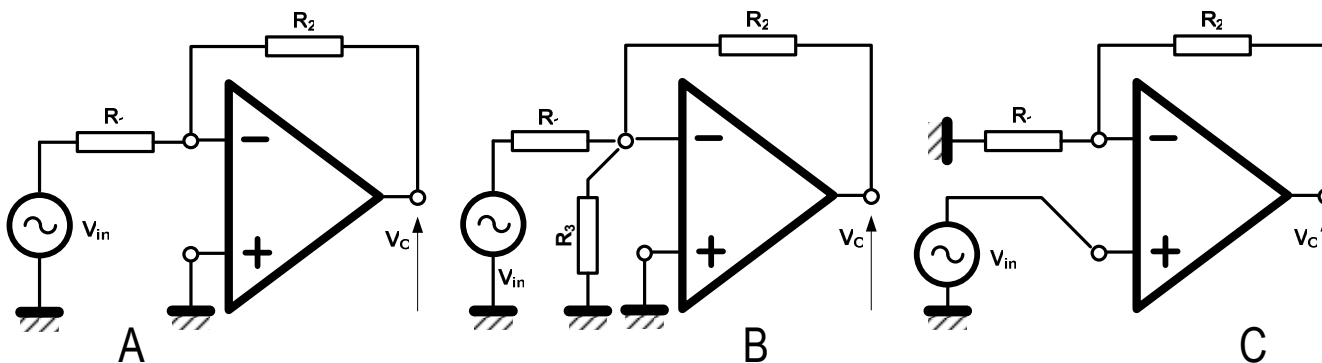

- Cuánto vale la T_{LC} en cada caso?
- Dada la T_{LC} , cuánto vale H en cada caso? ($G.H \gg 1$)
- Afecta R_3 la estabilidad del caso B?
- Si H_A difiere de H_B , la entrada V_{in} afecta la estabilidad de ambos?

- Por qué un modelo con cuadripolos?
- Qué tipo de cuadripolos se emplearían para el análisis?
- Qué resultados se esperan obtener del análisis?
- Qué tan exacto es el análisis con este modelo?
- Por qué un modelo Norton para la salida del AOV?

Modelo General

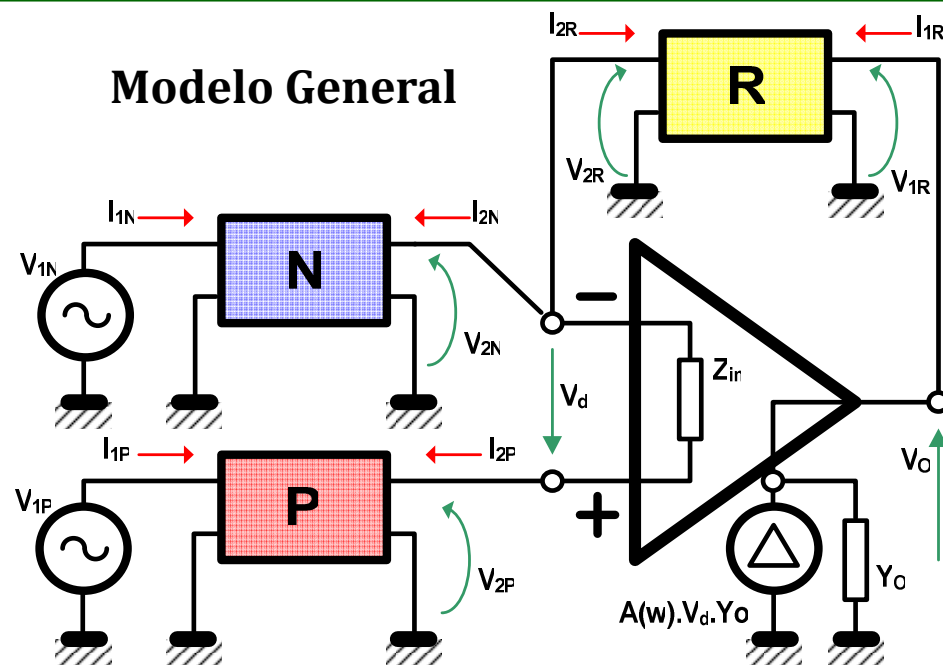

SISTEMAS DE CONTROL



Análisis general de AOV realimentados: cont.

PARAMETROS ADMITANCIA

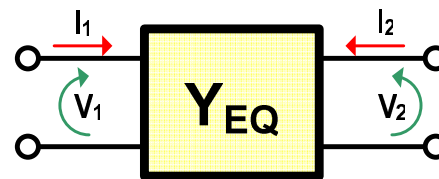
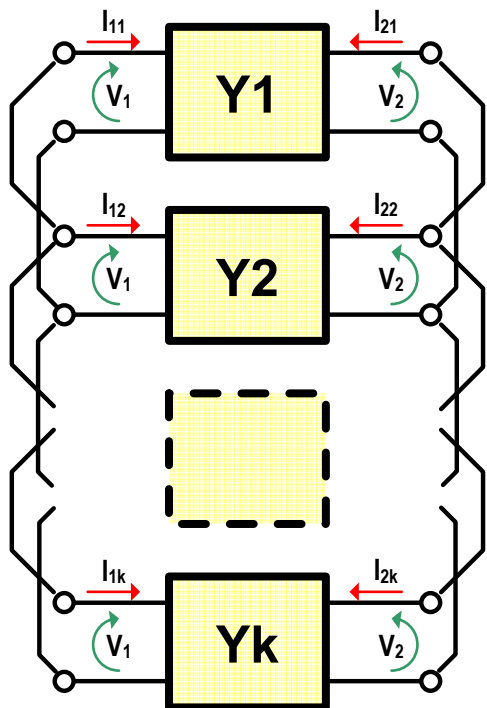

$$\begin{cases} i_1 = v_1 \cdot y_{11} + v_2 \cdot y_{12} \\ i_2 = v_1 \cdot y_{21} + v_2 \cdot y_{22} \end{cases}$$

$$I = \sum_{j=1}^k Y_j \cdot V = Y_{EQ} \cdot V$$

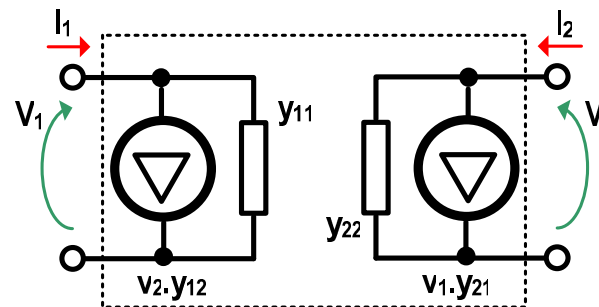

$$y_{11} = \left. \frac{i_1}{v_1} \right|_{v_2=0}$$
$$y_{12} = \left. \frac{i_1}{v_2} \right|_{v_1=0}$$
$$y_{21} = \left. \frac{i_2}{v_1} \right|_{v_2=0}$$
$$y_{22} = \left. \frac{i_2}{v_2} \right|_{v_1=0}$$





Análisis general de AOV realimentados: cont.

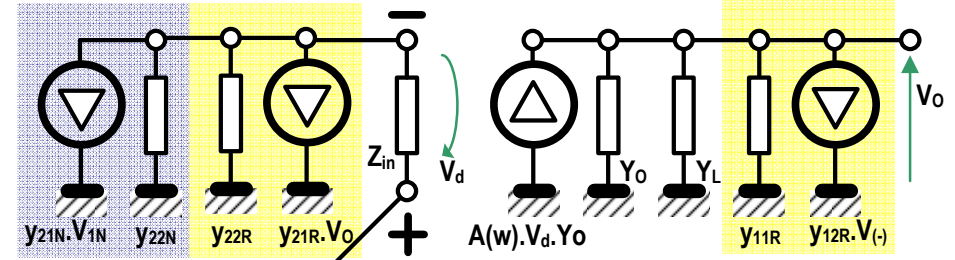
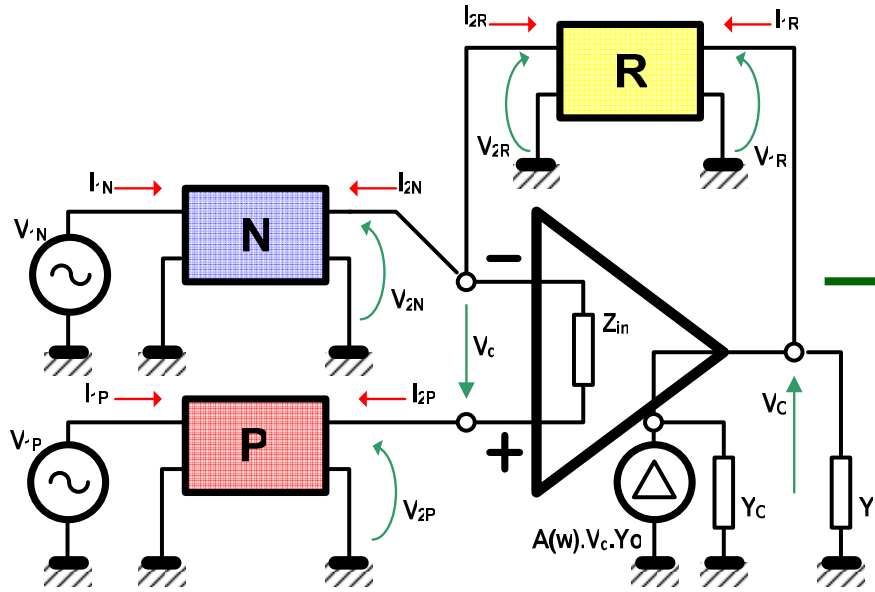

Modelo equivalente con parámetros Y

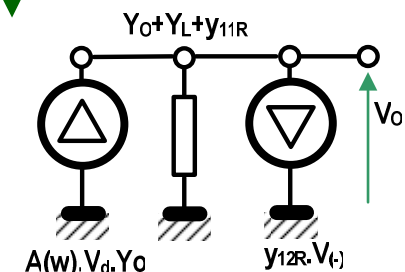
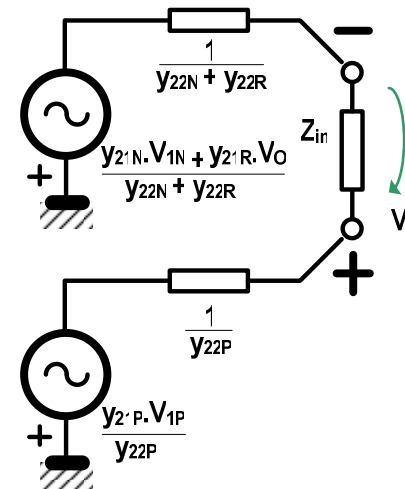
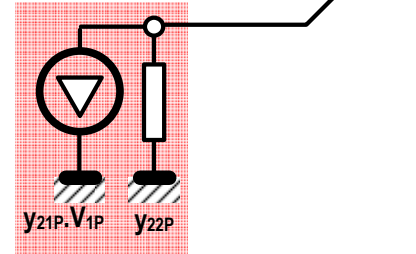

Definiciones:

$$F.E. = \frac{Z_{in}}{Z_{in} + y_{22P}^{-1} + (y_{22N} + y_{22R})^{-1}} \approx 1$$

$$F.S. = \frac{1}{y_{11R}^{-1} + Y_O + Y_L} \approx \frac{1}{Y_O}$$

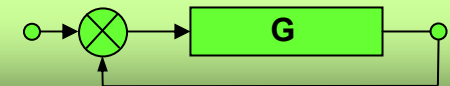



Análisis general de AOV realimentados: cont.

Suposiciones simplificadorias:

- La ganancia de avance de la red R es despreciable (y_{12R}).
- La impedancia de entrada del AOV es infinita (Z_{in}).
- La admitancia de salida del AOV es mucho mayor que la admitancia de carga ($Y_0 \gg Y_L + y_{11R}$)

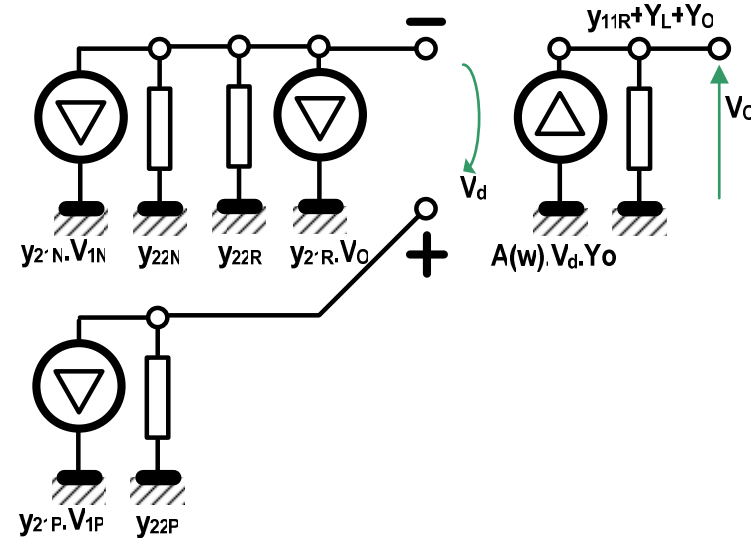

Atención a los signos +/- !

$$H = \frac{-y_{21R}}{y_{22N} + y_{22R}}$$

$$\frac{V_o}{V_{1P}} \cong \frac{A_{O(\omega)}}{1 + A_{O(\omega)} \cdot H} \cdot \left(\frac{-y_{21P}}{y_{22P}} \right)$$

$$\frac{V_o}{V_{1N}} \cong \frac{A_{O(\omega)}}{1 + A_{O(\omega)} \cdot H} \cdot \left(\frac{y_{21N}}{y_{22N} + y_{22R}} \right)$$

Modelo equivalente simplificado

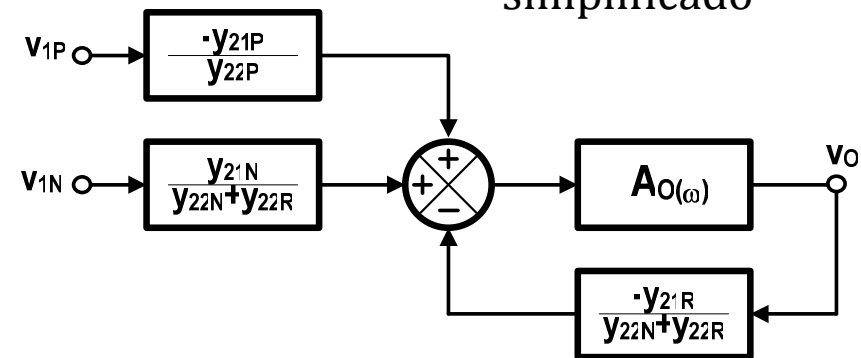



Análisis general de AOV realimentados: cont.

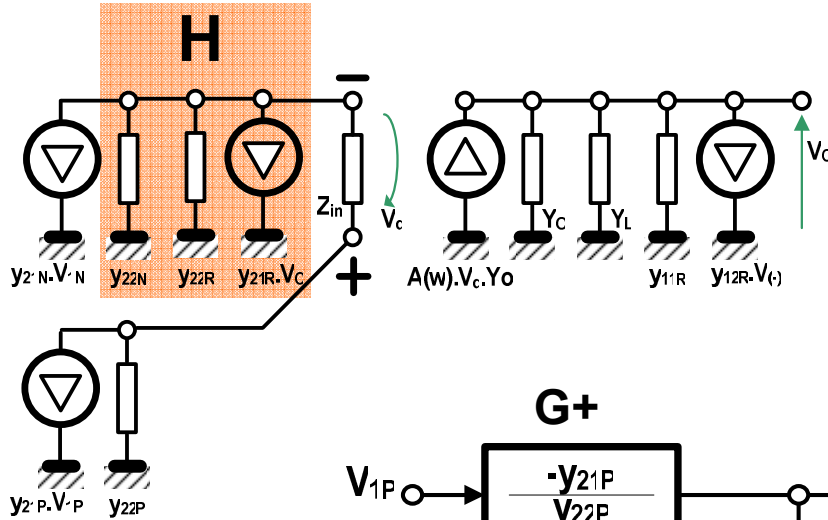

$$F.E. = \frac{Z_{in}}{Z_{in} + y_{22P}^{-1} + (y_{22N} + y_{22R})^{-1}} \approx 1$$

$$F.S. = \frac{1}{y_{11R}^{-1} + Y_O + Y_L} \approx \frac{1}{Y_O}$$

Efecto de la transferencia de avance del cuadrupolo de realimentación

Modelo equivalente general

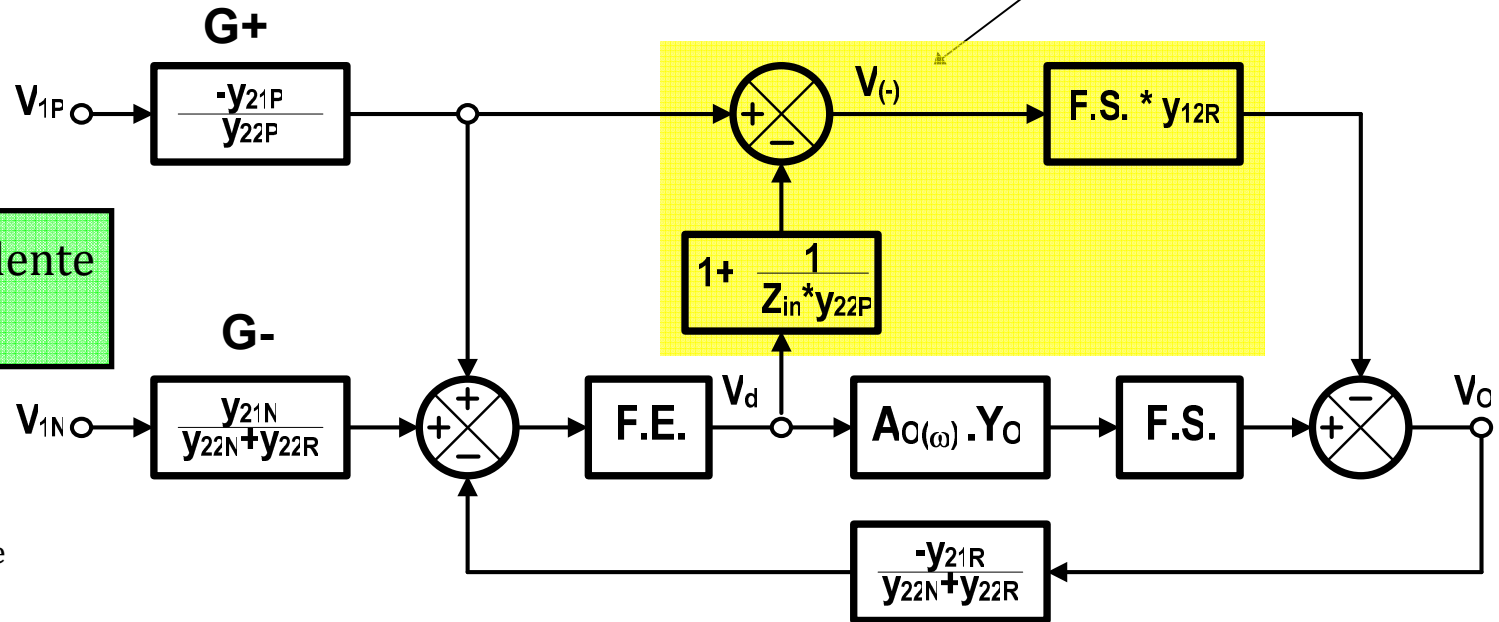

Resolución mediante
Fórmula de Mason?





Análisis general de AOV realimentados: cont.

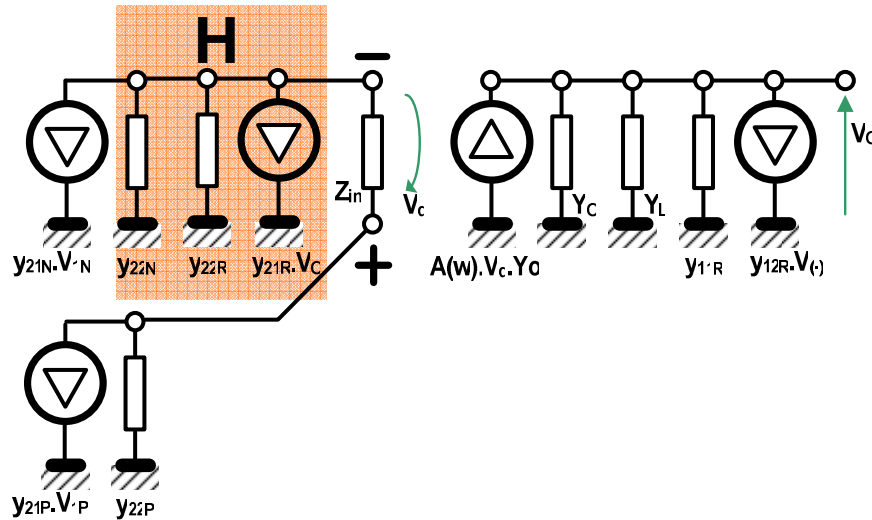

Corolario del modelo exacto:

$$H = - \frac{y_{21R}}{y_{22N} + y_{22R}}$$

- Cuánto vale la T_{LC} sólo con entrada en pin inversor cuando $G \cdot H \gg 0dB$ despreciando y_{12R} ?
- Cuánto vale la T_{LC} sólo con entrada en pin no inversor cuando $G \cdot H \gg 0dB$ despreciando y_{12R} ?

Ejemplo: Simple Inversor

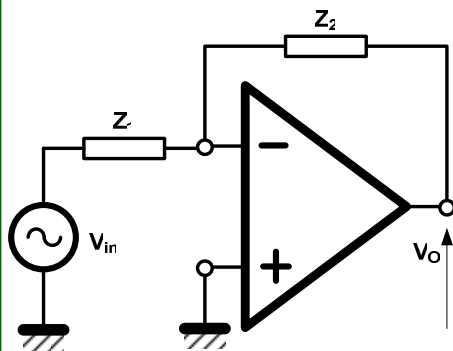

$$G_{-} = \frac{y_{21N}}{y_{22N} + y_{22R}} \quad \left| \quad \begin{aligned} y_{21N} &= -\frac{1}{Z_1} \\ y_{21R} &= -\frac{1}{Z_2} \\ y_{22R} &= \frac{1}{Z_2} \\ y_{22N} &= \frac{1}{Z_1} \end{aligned} \right. \quad \left| \quad \begin{aligned} G_{-} &= \frac{-Z_2}{Z_1 + Z_2} \\ H &= \frac{Z_1}{Z_1 + Z_2} \end{aligned}$$

$$T_{LC} \approx -\frac{y_{21N}}{y_{21R}} = -\frac{Z_2}{Z_1}$$

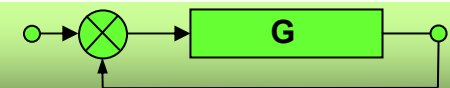
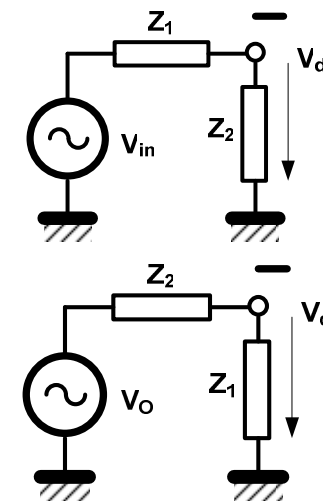



Análisis general de AOV realimentados: cont.

- Qué ocurre si $R_o < R$? Es estable?
- A qué frecuencia se tiene $GH=0dB$?
- Cuánto vale T_{LC} para $\omega \rightarrow \infty$
- Por qué la realimentación se vuelve +?
- Dibujar G.H

Ejemplo: Integrador real con AOV internamente compensado

$$H = \frac{R}{R + 1/s.C} = \frac{s.C.R}{1 + s.C.R}$$

$$G_- = \frac{-1/s.C}{R + 1/s.C} = \frac{-1}{1 + s.C.R}$$

$$F.S. = \frac{1}{s.C + 1/R_o} = \frac{R_o}{1 + s.C.R_o}$$

$$F.E. \approx 1 \quad y_{12R} = -s.C$$

